

SECTION A-A

REINFORCEMENT REQUIRED
WHEN E=48" OR MORE.
NO.4 BARS @ 6" O.C.
EACH WAY. (HORZ) TYP 4
SIDES SEE NOTE 6.

NO.4 BARS @ 12" O.C.
EACH WAY. (VERT) TYP 4
SIDES

NO.4 BARS @
8" O.C. EACH
WAY.

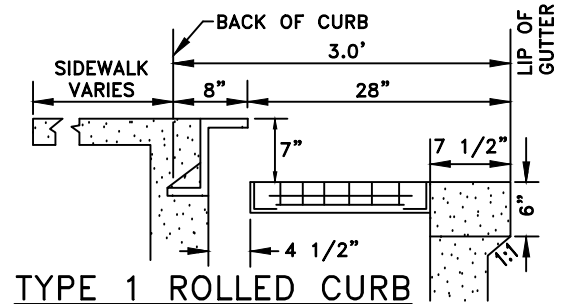

TYPE 1 ROLLED CURB

NOTES:

1. DIMENSIONS D AND E MAY VARY WITH EACH LOCATION.
2. SEE STANDARD DETAIL DR-9 FOR INLET GRATE.
3. THE INSIDE SURFACE OF FRONT AND BACK WALLS OF THE CATCH BASIN SHALL NOT DEVIATE MORE THEN 2" IN ALIGNMENT FROM INSIDE SURFACE OF THE WALLS OF THE TOP INLET PORTION.
4. SLOPE FLOOR 2" TO OUTLET.
5. CONCRETE SHALL BE "MINOR CONCRETE" AS DESCRIBED IN 71-5B OF THESE STANDARDS.
6. 6X6, 4 GAUGE WELDED WIRE FABRIC MAY BE USED IN LIEU OF #4 REBAR.
7. ALL REINFORCEMENT BAR SHALL BE GRADE 60.
8. CURB TRANSITION LENGTH FROM EACH SIDE OF DROP INLET TO STANDARD HEIGHT CURB SHALL BE 4'. MATCH DEEP TOOL JOINTS AND SCORE MARKS WITH CURB, GUTTER, AND SIDEWALK AS APPROPRIATE.
10. PIPE CONNECTIONS TO STRUCTURE SHALL BE MADE BY 12"X12" MINOR CONCRETE COLLARS.

"NO DUMPING"
SEE DETAIL
DR-20

12" EACH SIDE
OF DRAIN
INLET. IF NOT
ADJOINING
SIDEWALK.

NO.4 BARS @
8" O.C. EACH
WAY.

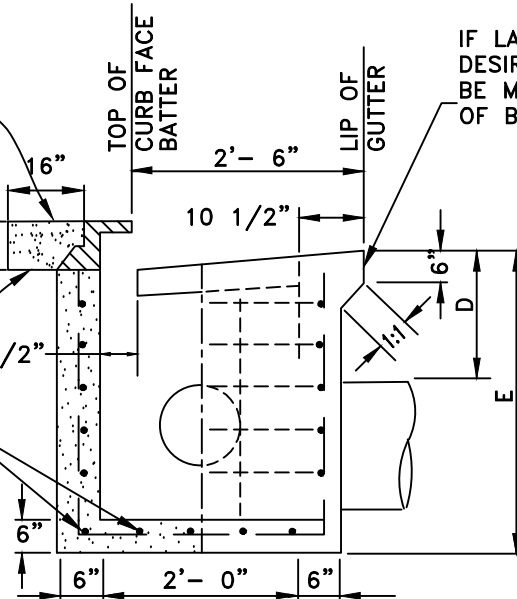

SECTION B-B

IF LARGER BOX IS
DESIRED FILLET CAN
BE MOVED TO INSIDE
OF BOX

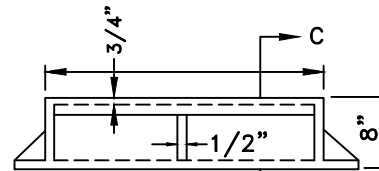

BONNET

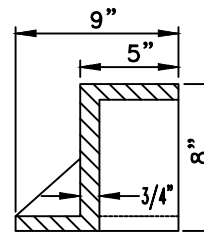

SECTION C-C

Marc Stout

MARC STOUT
CITY ENGINEER

CITY OF
ROSEVILLE
CALIFORNIA
DEVELOPMENT SERVICES
DEPARTMENT

DROP INLET
TYPE "C"

FRAME, HOOD AND GRATE (OR APPROVED EQUAL APPLIES)
D&L SUPPLY: #FA-8543-R1 (FRAME), #FA-8543-02 (GRATE), #13541 (HOOD)
SOUTH BAY FOUNDRY: #1904 (FRAME, GRATE, HOOD)
HALM METAL FAB:#13542(FRAME), #13543 (GRATE), #13541 (HOOD)

SCALE: NONE
REVISED: May 10, 2021
DRAWN BY: R MEDINA
APPROVED BY: MARC STOUT

DR-1

DEPTH IN FEET AT GUTTER FLOWLINE (SUMP)

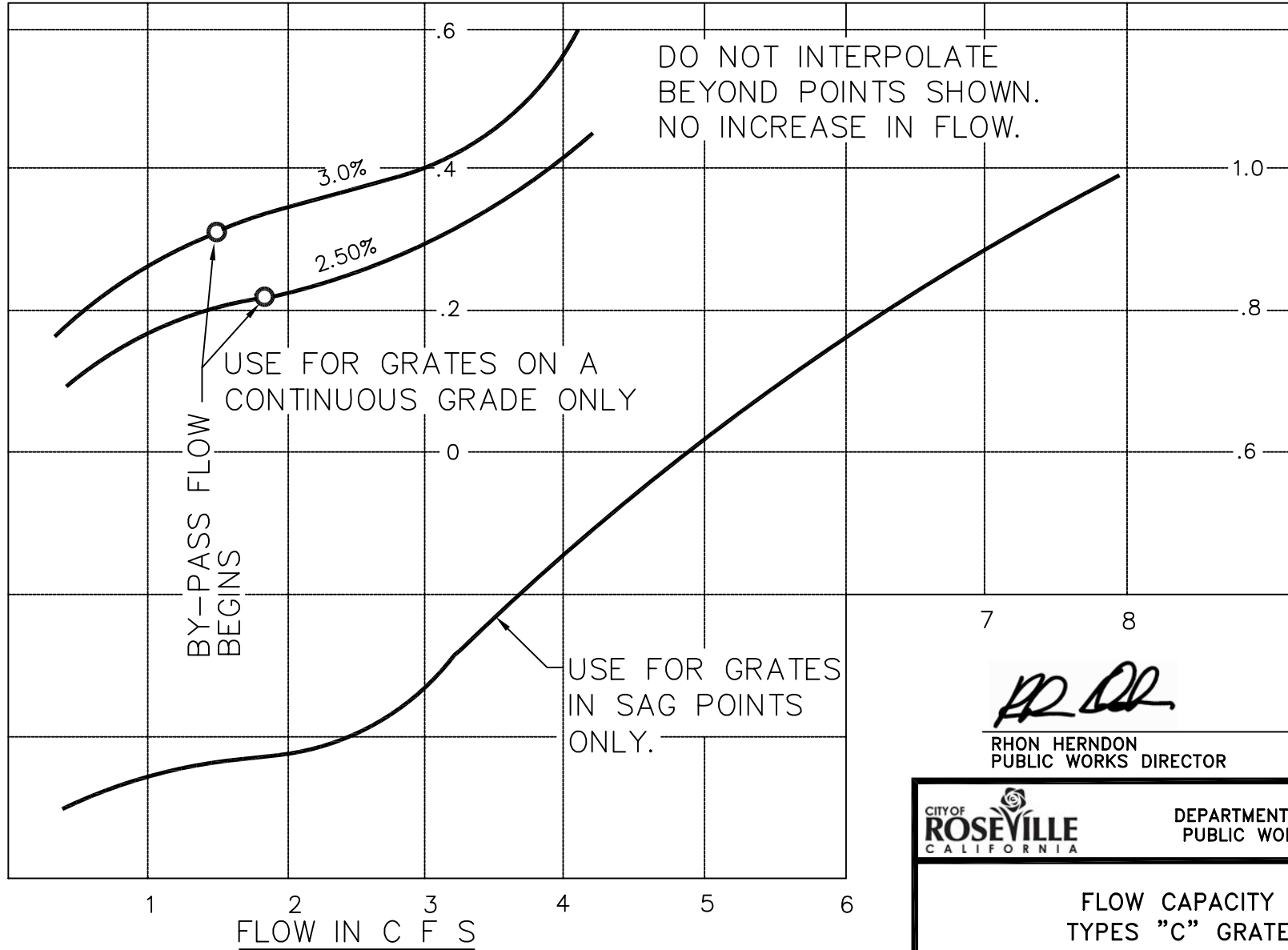

RHON HERNDON
PUBLIC WORKS DIRECTOR



DEPARTMENT OF
PUBLIC WORKS

FLOW CAPACITY
TYPES "C" GRATE

SCALE: NONE
REVISED: JANUARY 1, 2010
DRAWN BY: J MCKINNEY
APPROVED BY: RHON HERNDON

DR-2

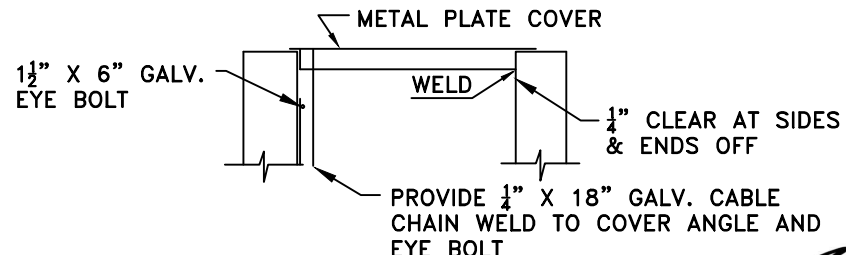
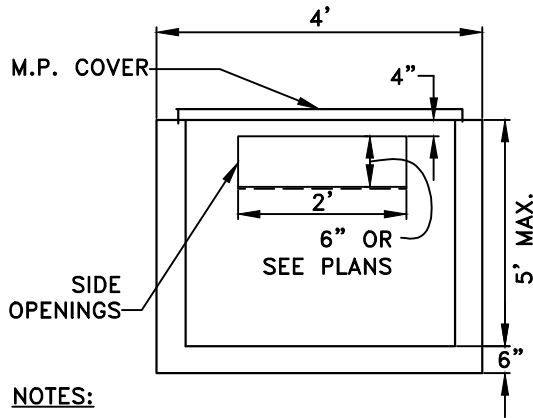
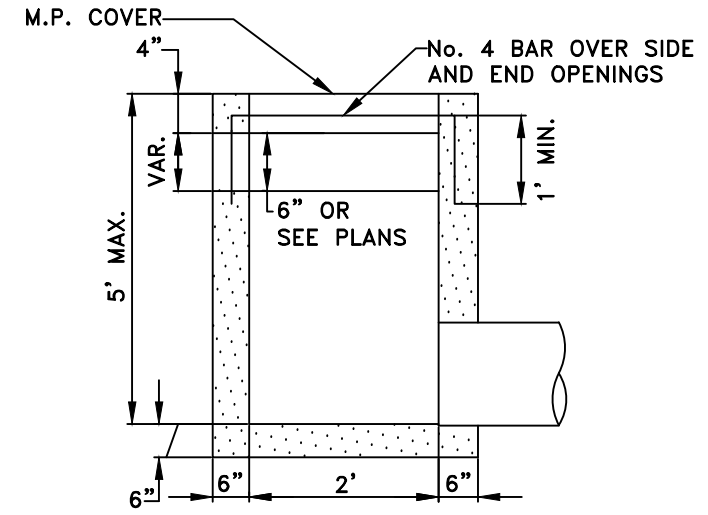
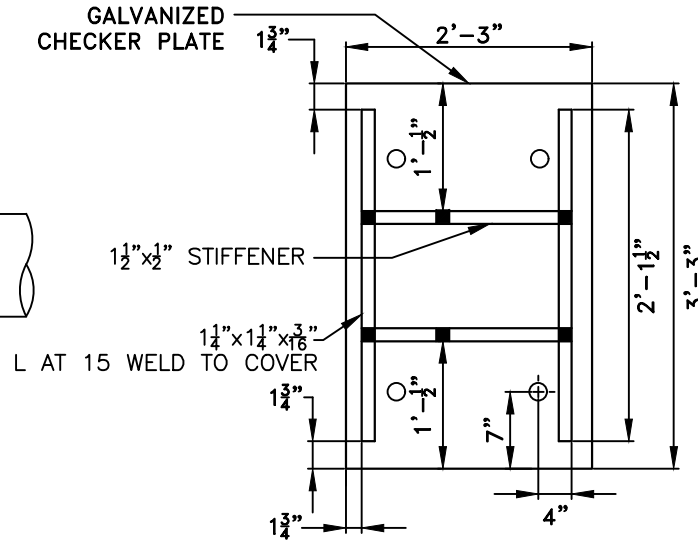
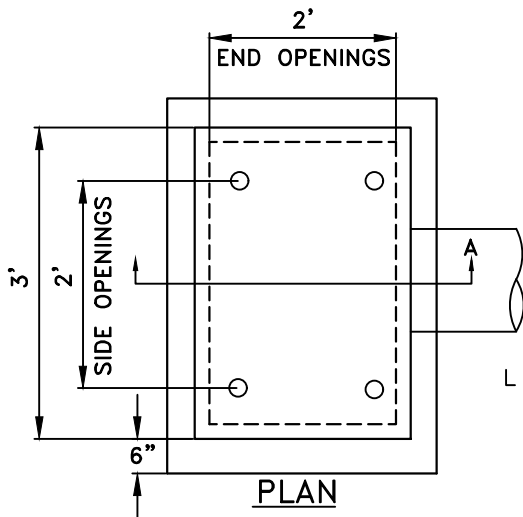

NOTE: METAL PLATE COVER TO BE D&L SUPPLY (FA-8452-01) OR APPROVED EQUAL)

NOTES:

1. METAL PLATE COVER TO BE GALVANIZED.
2. THIS STRUCTURE TO BE USED ONLY TO PICKUP ON SITE DRAINAGE ON PRIVATE PROPERTY UNLESS SPECIFICALLY APPROVED BY THE DIRECTOR.
3. DRAIN INLETS NOT WITHIN A PAVED AREA SHALL HAVE A 12" WIDE COLLAR OF 6" THICK CONCRETE.
4. THE INSIDE SURFACE OF FRONT AND BACK WALLS OF THE CATCH BASIN SHALL NOT DEVIATE MORE THEN 2" OF VERTICAL ALIGNMENT.
5. SLOPE FLOOR 2" TO OUTLET.
6. ALL CONCRETE SHALL BE "MINOR CONCRETE" AS DEFINED IN SECTION 71-5B OF THESE STANDARDS.
7. PROVIDE END OR SIDE OPENINGS AS SHOWN ELSEWHERE ON PLANS OR CROSS SECTIONS.
8. TOP OF ALL WALLS SHALL BE FINISHED TO A LEVEL PAN TO PROVIDE EVEN BEARING FOR PLATE COVER.
9. SEE DETAIL DR-1 FOR REINFORCEMENT REQUIREMENTS.
10. PIPE CONNECTIONS TO STRUCTURE SHALL BE MADE BY 12"x12" MINOR CONCRETE COLLARS.

MARC STOUT
CITY ENGINEER

	DEVELOPMENT SERVICES DEPARTMENT
<h2 style="margin: 0;">DROP INLET TYPE "F"</h2>	
SCALE: NONE REVISED: JANUARY 1, 2020 DRAWN BY: R MEDINA APPROVED BY: MARC STOUT	<h3 style="margin: 0;">DR-3</h3>

TABLE OF DIMENSIONS

A	B	T MIN.	BASE
48"	18"	6"	6"
60"	30"	8"	8"
72"	42"	8"	8"
84"	54"	12"	8"
96"	12" (FLAT)	12"	8"

DIMENSION "B" IS A MINIMUM DIMENSION AND MAY BE GREATER IF DEPTH PERMITS.

RISER SECTIONS, CONES, AND ADJUSTING RINGS SHALL CONFORM TO ASTM DESIGNATION C-478

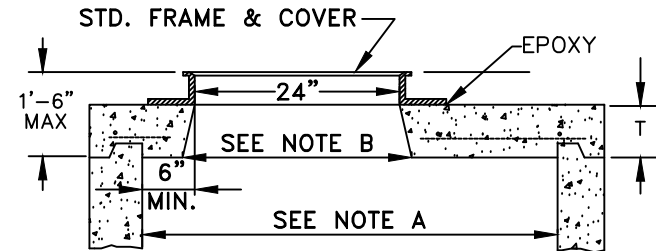
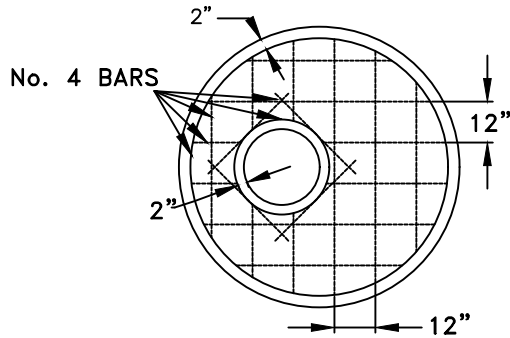

- A. A FLAT TOP SLAB SHALL BE USED WHEN A SHALLOW LINE DOES NOT PERMIT USE OF A TAPERED CONE. NO CONCRETE COLLAR REQUIRED.
- B. IF THE BOTTOM, INSIDE DIAMETER OF THE FLAT TOP OPENING IS 28 INCHES OR MORE, THE THICKNESS OF THE SLAB MAY BE DISREGARDED IN COMPUTING THE MAXIMUM 18 INCH HEIGHT OF THE OPENING.

FLAT TOP SLAB

NOTES:

1. ECCENTRIC CONES SHALL BE USED WHERE SPECIFIED ON THE PLANS.
2. JOINT MAY BE EITHER KEYED OR TONGUE AND GROOVE.
3. SEE SECTION 101-8 (MATERIALS) FOR JOINT COMPOUND. (ALL MANHOLE JOINTS)
4. TOP OF FRAME SHALL BE 1/8 INCH BELOW ADJACENT PAVEMENT. (PER 101-4.F)
5. 0.20 FOOT MINIMUM FALL THROUGH MANHOLE.
6. O.D. OF PIPE SHALL NOT EXCEED I.D. OF ITS MANHOLE BARREL.
7. WHERE SHORT 24" FRAMES ARE USED, TO ACHIEVE FULL 3 INCH PAVEMENT PATCH SLOPE CONCRETE FROM BASE OF FRAME TO 3 INCHES BELOW FINISH GRADE.
8. PIPE CONNECTIONS TO STRUCTURE SHALL BE MADE BY 12"x12" MINOR CONCRETE COLLARS.
9. CONCRETE COLLAR AROUND RIM SHALL BE BROUGHT TO SURFACE FINISH GRADE FOR ALL COLLECTORS AND ARTERIALS, OPTIONAL IN ALL OTHER ROADWAYS. FINISH SURFACE SHALL BE MEDIUM BROOM FINISH WITH PATTERN PERPENDICULAR TO VEHICLE TRAVEL DIRECTION.

3" PAVEMENT PATCH OR MINOR CONCRETE PER SECTION 101-4.F FOR FINISH GRADE REQUIREMENTS

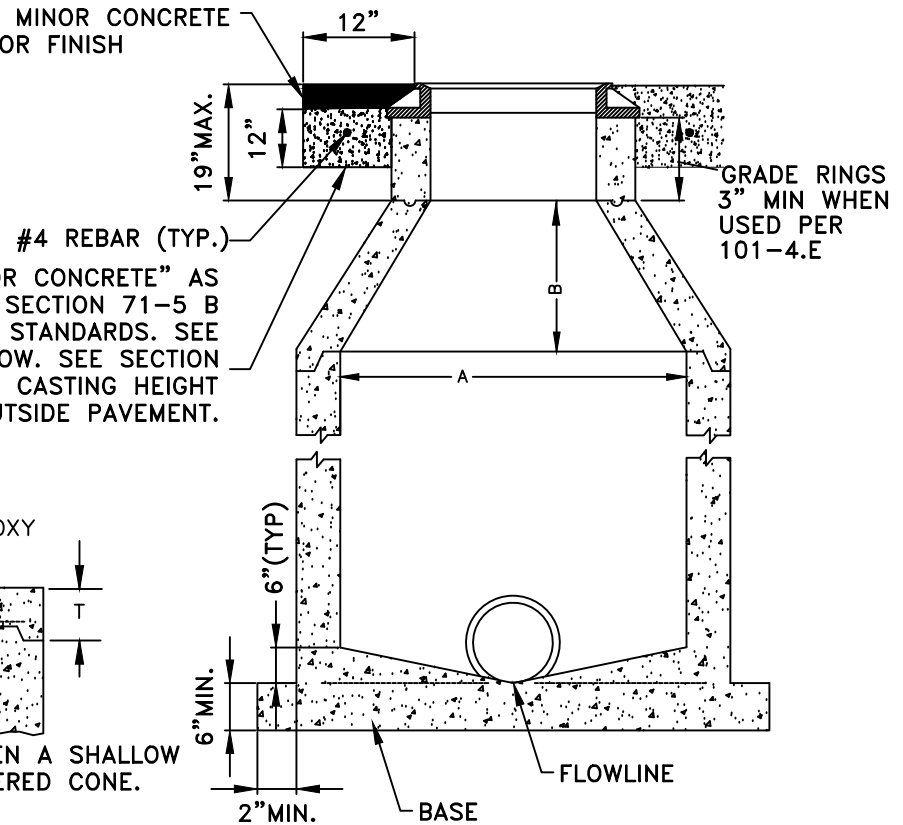

MARC STOUT
CITY ENGINEER

<p>CITY OF ROSEVILLE CALIFORNIA</p>	<p>DEVELOPMENT SERVICES DEPARTMENT</p>
<p>STANDARD PRECAST MANHOLE (DRAINAGE)</p>	
<p>SCALE: NONE REVISED: MARCH 1, 2024 DRAWN BY: R MEDINA APPROVED BY: MARC STOUT</p>	
<p>DR-4</p>	

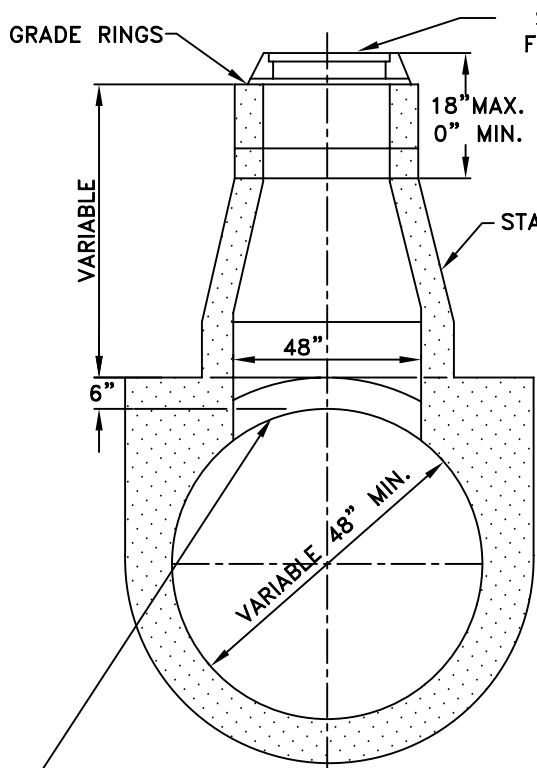

TYPE A
CAST-IN-PLACE PIPE ONLY

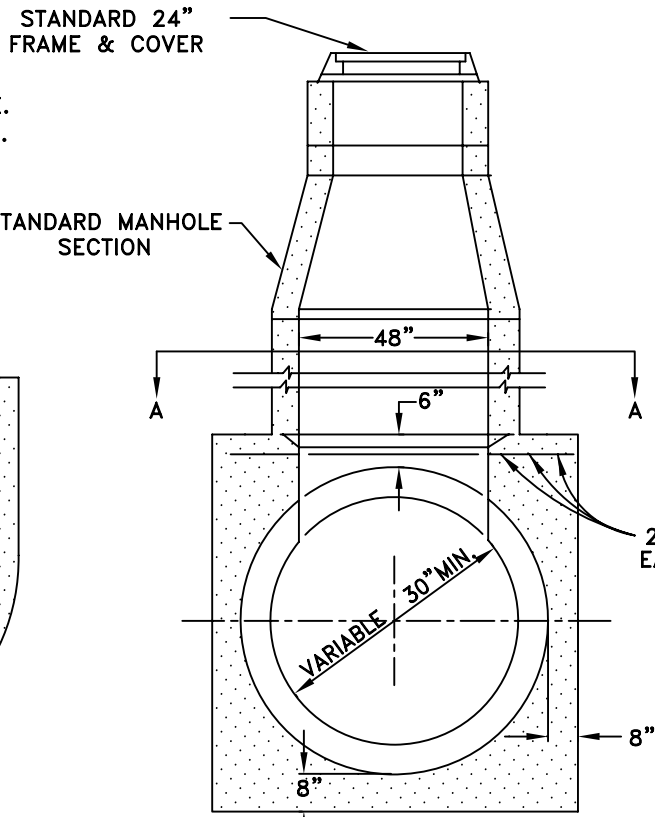

TYPE B

1. ALL PIPE OTHER THAN CAST-IN-PLACE PIPE
2. CAST-IN-PLACE PIPE LESS THAN 48" DIA.

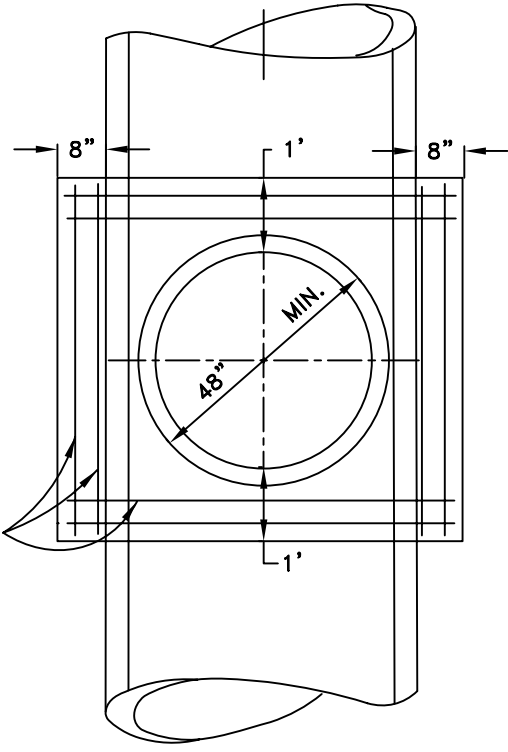

SECTION A-A

RHON HERNDON

RHON HERNDON
PUBLIC WORKS DIRECTOR

NOTE:
REMOVE CONCRETE IN MANHOLE OPENING
AND CONSTRUCTION RISER BASE WHILE
CONCRETE IS STILL FRESH

PLACE RISER SECTION AFTER CONCRETE
HAS SET

	DEPARTMENT OF PUBLIC WORKS
<p>TYPE A & B SADDLE MANHOLE</p>	
SCALE: NONE REVISED: JANUARY 1, 2013 DRAWN BY: J MCKINNEY APPROVED BY: RHON HERNDON	
DR-5	

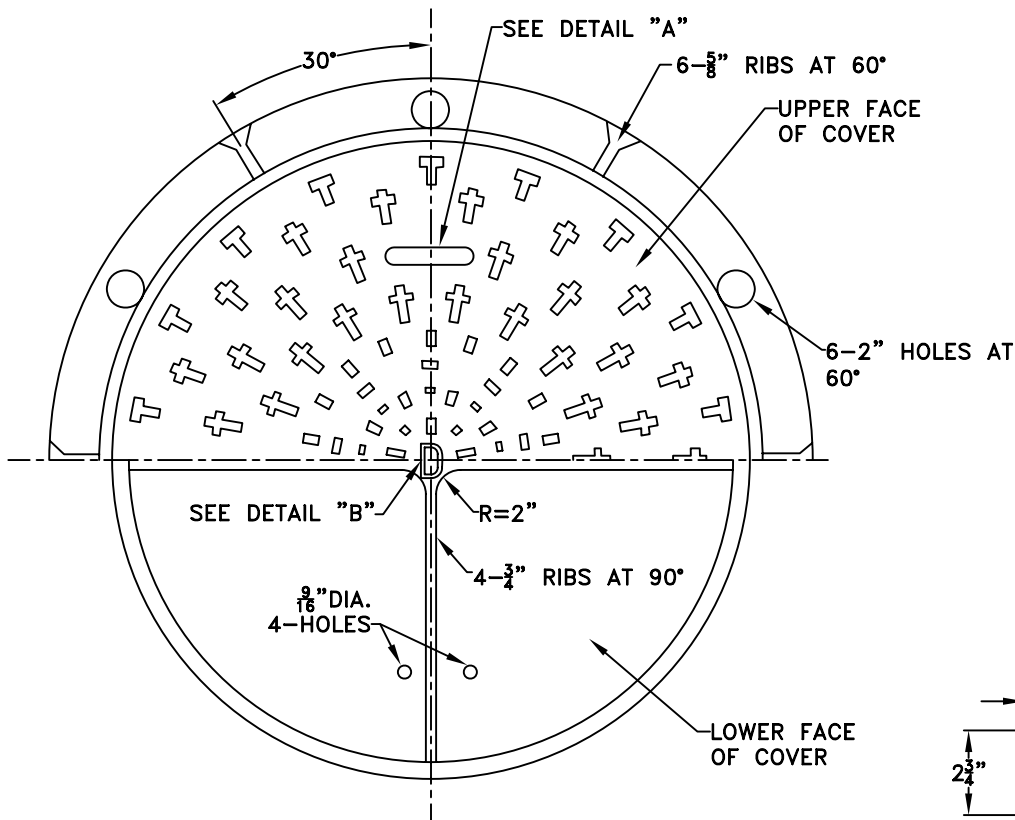

HALF PLAN OF MANHOLE COVER AND FRAME

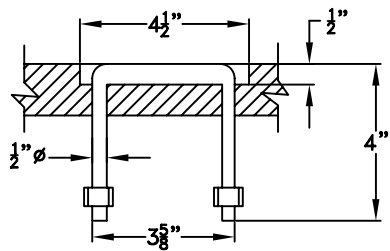

DETAIL "A" HANDLE

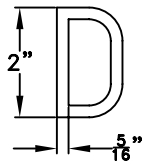

DETAIL "B"
LETTER 'D' AT CENTER OF COVER

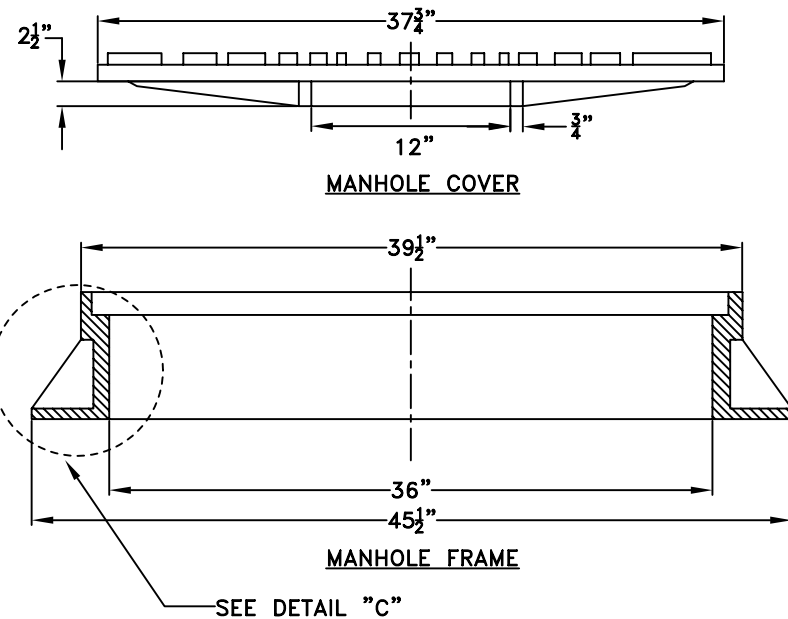

NOTE:

FRAME WT. APPROX. 300 LBS.
COVER WT. APPROX. 375 LBS.

RHON HERNDON
PUBLIC WORKS DIRECTOR



DEPARTMENT OF
PUBLIC WORKS

STANDARD 36" MANHOLE
FRAME AND COVER

NOTES:

1. ALL MANHOLE COVERS ARE TO HAVE A ANTI SKID PATTERN
2. SEE SECTION 101-8 MATERIALS OF THE THESE CONSTRUCTION STANDARDS (DR 9 of 11) FOR APPROVED FRAME AND COVERS.

SCALE: NONE
REVISED: JANUARY 1, 2010
DRAWN BY: J MCKINNEY
APPROVED BY: RHON HERNDON

DR-7

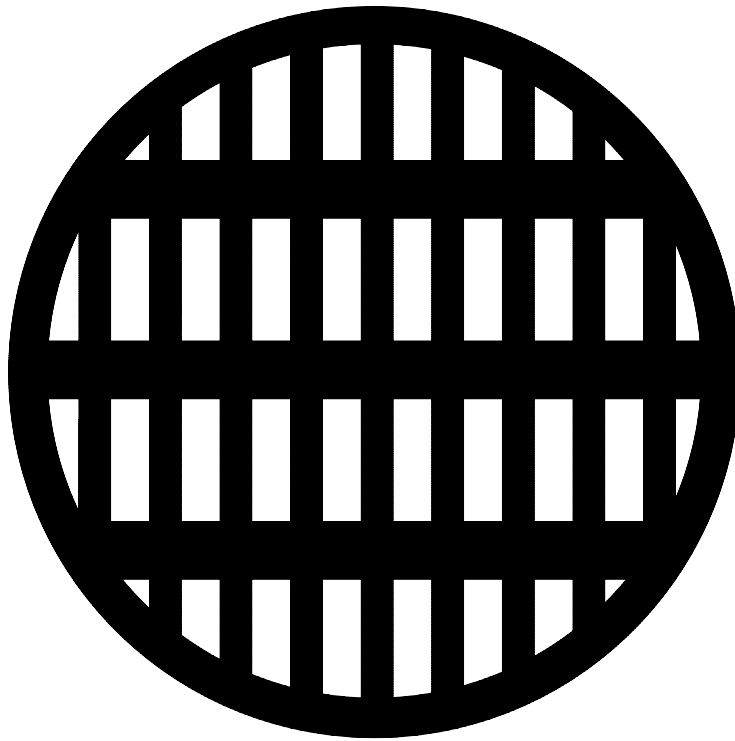

DRAIN INLET FRAME AND COVER ASSEMBLIES
(OR APPROVED EQUAL APPLIES)

D&L SUPPLY: #C-2660 (6 5/8 INCH HIGH STANDARD CASTING), #C-2661 (5 INCH), #C-2662 (3 INCH)
SOUTH BAY FOUNDRY: #1920 (6 5/8 INCH), #1922 (5 INCH), #1923 (3 INCH), (SPECIFY DRAIN INLET TYPE)

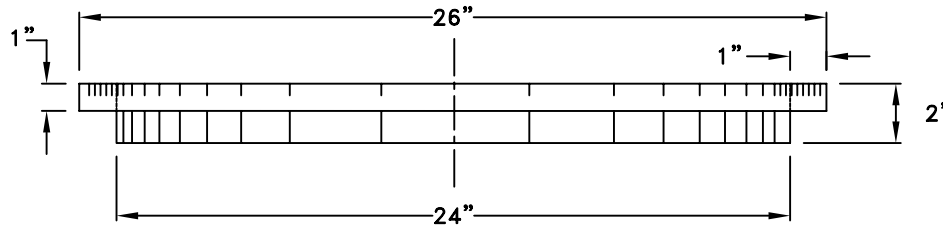

RHON HERNDON
PUBLIC WORKS DIRECTOR

		DEPARTMENT OF PUBLIC WORKS
GRATE TYPE MANHOLE COVER		
SCALE: NONE REVISED: JANUARY 1, 2010 DRAWN BY: J MCKINNEY APPROVED BY: RHON HERNDON		DR-8

NOTES:

1. DRAIN INLET AND NON DRAIN INLET FRAMES ARE IDENTICAL.
2. A SHORT FRAME REQUIRES APPROVAL OF THE PUBLIC WORKS INSPECTOR

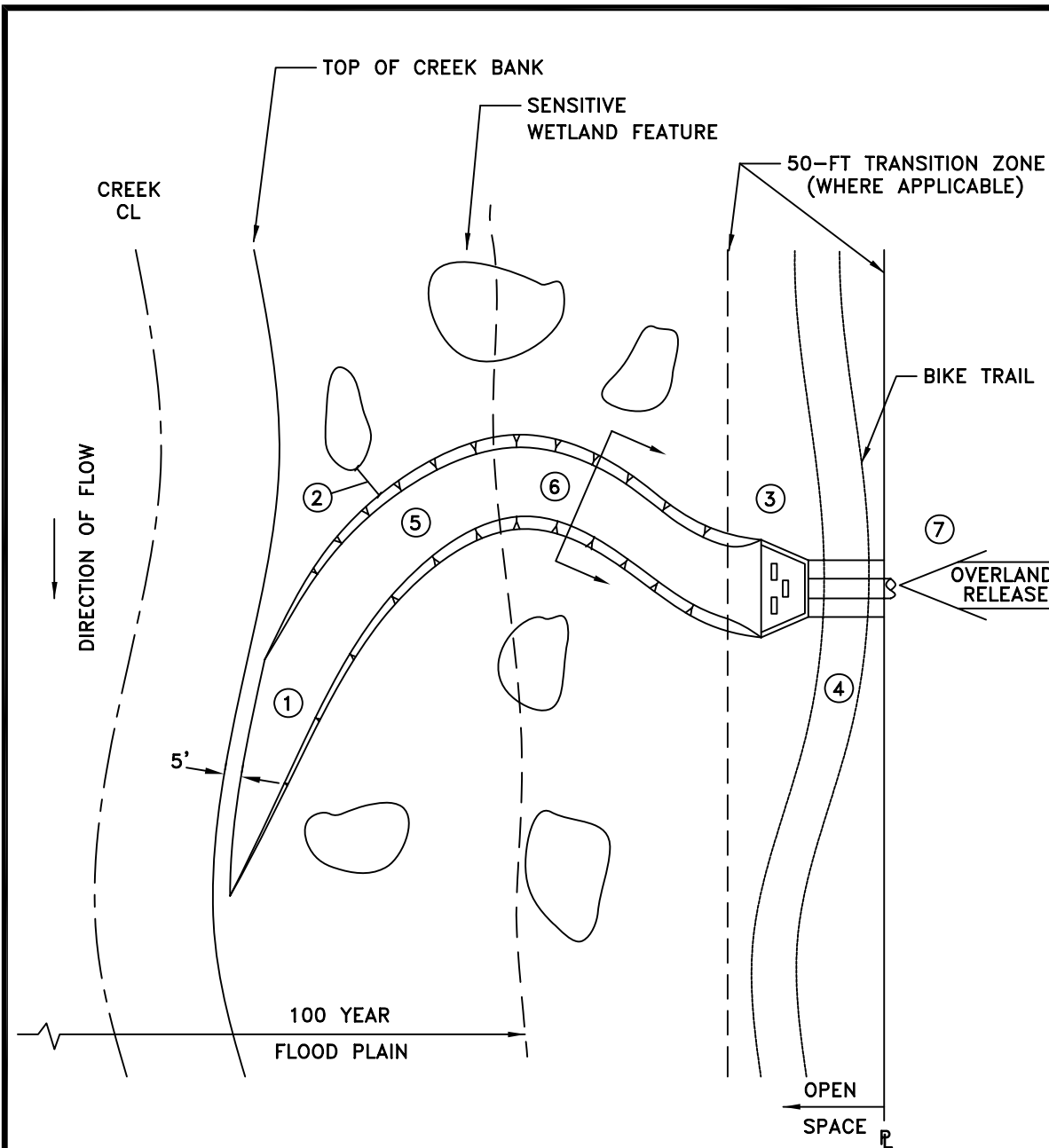

NOTES:

- ① DRAINAGE SWALE (DR-11) SHALL DAYLIGHT 5-FT PRIOR TO TOP OF CREEK BANK. FLOW VELOCITY SHALL BE AT 2 FPS PRIOR TO DAYLIGHT.
- ② EDGE OF DRAINAGE SWALE SHALL REMAIN A MINIMUM OF 5-FT FROM ANY SENSITIVE WETLAND FEATURES.
- ③ OUTFALL STRUCTURE (DR-12) MAY BE PLACED WITHIN 50-FT TRANSITION ZONE. IN AREAS WHERE A TRANSITION ZONE DOES NOT EXIST, THE LOCATION OF THE OUTFALL STRUCTURE SHALL BE ONSITE OR AS APPROVED BY THE CITY ENGINEER.
- ④ IF A BIKE TRAIL IS LOCATED WITHIN THE OPEN SPACE, THEN THE OUTFALL STRUCTURE SHALL BE PLACED ON THE STREAM SIDE OF THE BIKE TRAIL.
- ⑤ VELOCITY CHECK DAMS DR-14 SHALL BE USED WHEN DESIGN FLOW VELOCITY EXCEEDS 5 FPS.
- ⑥ SEE STANDARD DETAIL DR-11 FOR SWALE CROSS SECTION.
- ⑦ OVERLAND RELEASE SHALL TIE INTO HEADWALL STRUCTURE PER DETAIL DR-12.
- ⑧ SWALE LENGTH IS A FUNCTION OF CONTACT TIME AS REQUIRED FOR STORM WATER TREATMENT.



RHON HERNDON

RHON HERNDON
PUBLIC WORKS DIRECTOR

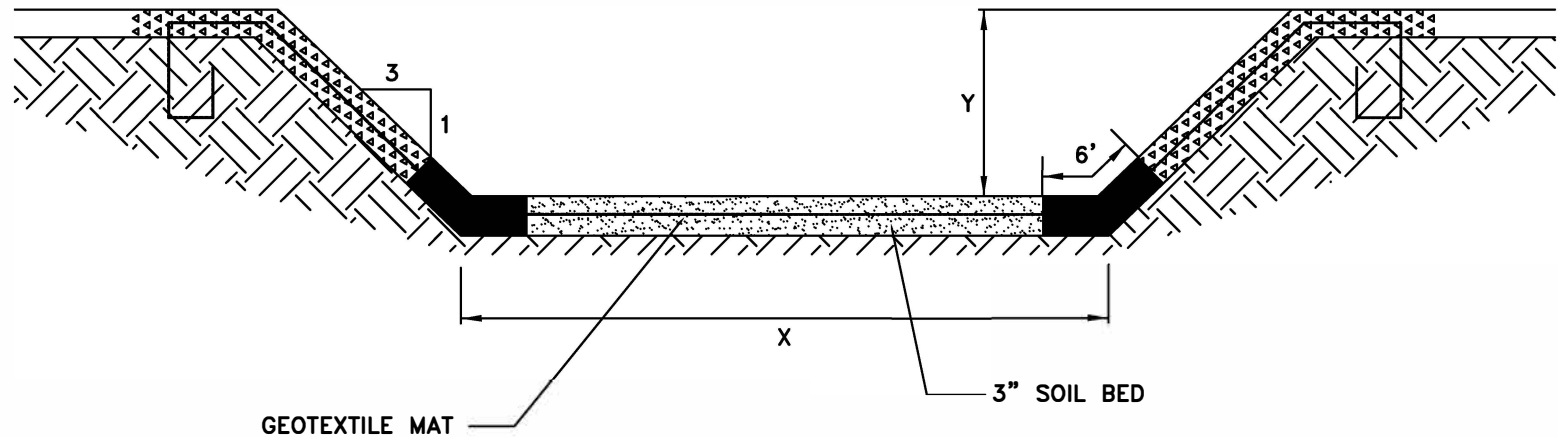
	DEPARTMENT OF PUBLIC WORKS
WATER QUALITY OUTFALL SWALE WITHIN OPEN SPACE	
SCALE: NONE REVISED: JANUARY 1, 2013 DRAWN BY: J MCKINNEY APPROVED BY: RHON HERNDON	
DR-10	



KEY:

-  SWALE/WET NATIVE SEED MIX
(SEE SECTION 11, GRADING FOR SEED MIX)
-  DRY NATIVE SEED MIX
(SEE SECTION 11, GRADING FOR SEED MIX)
-  SWALE/WET AND DRY SEED MIX

- X CHANNEL BASE
- Y CHANNEL DEPTH

NOTES

1. PYRAMAT HPTRM OR APPROVED EQUAL SHALL BE PLACED ON TOP OF 3-IN SEEDED SOIL BED AND WILL BE INSTALLED PER THE MANUFACTURE'S SPECIFICATIONS. FOR CHANNEL VELOCITIES LESS THAN 5 FPS, THE PYRAMAT HTRM MAY BE REPLACED WITH A BIODEGRADABLE MATTING (I.E. COCONUT MATTING) THE BIODEGRADABLE MATTING SHALL A MINIMUM 3 YEAR LIFE.
2. WETLAND AND UPLAND SEEDING SHALL OVERLAP AT THE TRAPEZOIDAL HINGE POINT.
3. IF SWALE IS BEING USED FOR STORM WATER TREATMENT, THEN THE CHANNEL GEOMETRIC DESIGN SHALL FOLLOW THE GUIDLINES FOR CONTACT TIME FROM THE STORMWATER QUALITY DESIGN MANUAL FOR THE SACRAMENTO AND SOUTH PLACER REGIONS.
4. ALL SWALES SHALL BE DESIGNED TO CONVEY THE 10-YEAR STORM EVENT.



MARC STOUT
CITY ENGINEER

CITY OF
ROSEVILLE
CALIFORNIA

DEVELOPMENT SERVICES
DEPARTMENT

**WATER QUALITY
OUTFALL SWALE**

SCALE: NONE
REVISED: FEBRUARY 1, 2020
DRAWN BY: J HENDRIX
APPROVED BY: MARC STOUT

DR-11

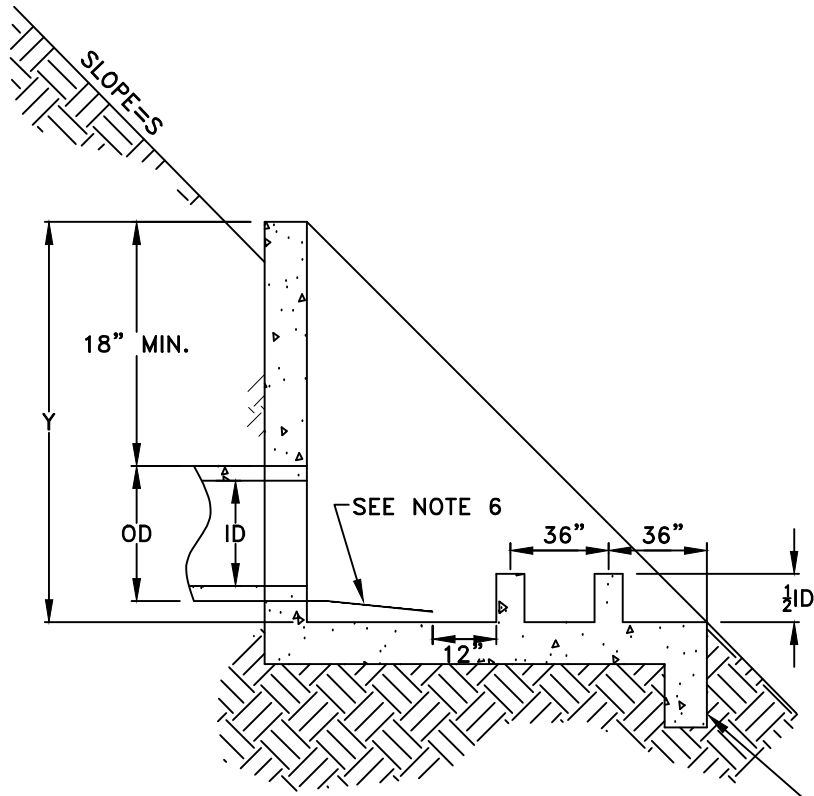

DEPTH BASED ON FIELD CONDITONS

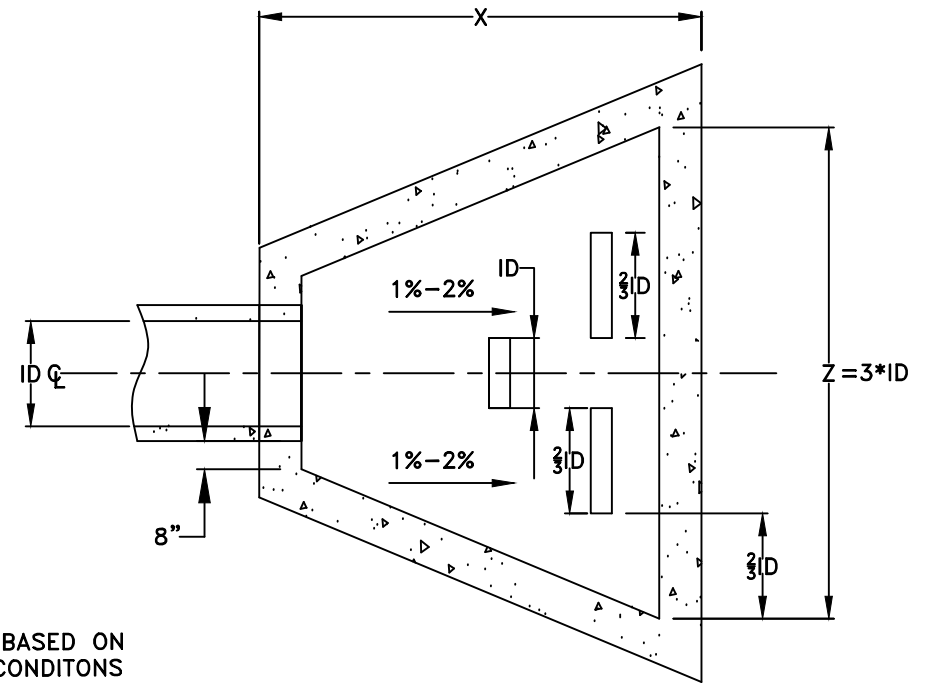

Marc Stout

MARC STOUT
CITY ENGINEER

NOTES:

1. HEADWALL DESIGN MUST MEET THE FOLLOWING CRITERIA:
 - A. $X = SY$ (IF FLAT SLOPE $S=1$)
 - B. $X \geq ID+6(FT)$
 - C. $Y \geq OD+2(FT)$
2. ALL CONCRETE SHALL BE MINIMUM 8" THICK
3. DESIGN ENGINEER SHALL PROVIDE A REBAR SCHEDULE FOR HEADWALLS LESS THAN 4 FEET IN HEIGHT
4. STRUCTURAL CALCULATIONS SHALL BE SUBMITTED FOR HEADWALLS 4 FEET OR GREATER IN HEIGHT
5. ALL CONCRETE TO BE "MINOR CONCRETE" AS DEFINED IN SECTION 71-5B OF THESE STANDARDS
6. REFER TO STANDARD DETAIL DR-16 FOR ACCESS CONTROL RACK REQUIREMENTS.
7. REFER TO DESIGN ENGINEER (STRUCTURAL) DESIGN WHERE FENCING IS REQUIRED.

 CITY OF ROSEVILLE CALIFORNIA	DEVELOPMENT SERVICES DEPARTMENT
<h2 style="margin: 0;">HEADWALL</h2>	
SCALE: NONE REVISED: JANUARY 1, 2025 DRAWN BY: J MCKINNEY APPROVED BY: MARC STOUT	
DR-12	

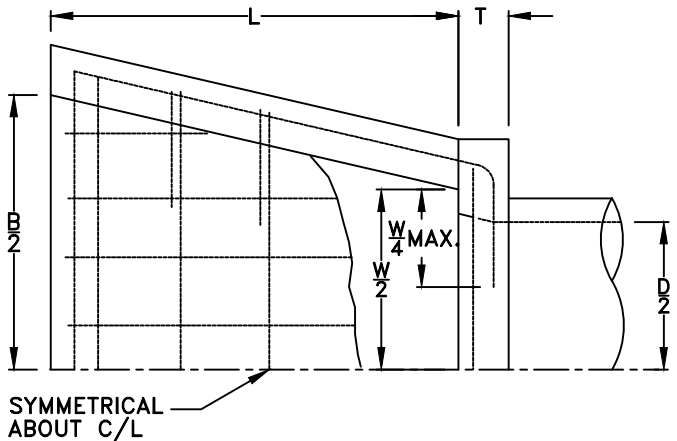

DIMENSIONS & REINFORCING

D	W	B	L	T	ALL REINFORCING
33"	3'- 5"	5'- 3"	4'- 0"	6"	# 5 @ 12"
36"	3'- 8"	5'- 8"	4'- 2"	6"	# 5 @ 12"
42"	4'- 4"	6'- 4"	4'- 8"	6"	# 5 @ 12"
48"	4'-10"	7'- 2"	5'- 2"	8"	# 6 @ 12"
54"	5'- 4"	8'- 0"	6'- 0"	8"	# 6 @ 12"
60"	6'- 0"	8'-10"	6'- 6"	8"	# 6 @ 12"

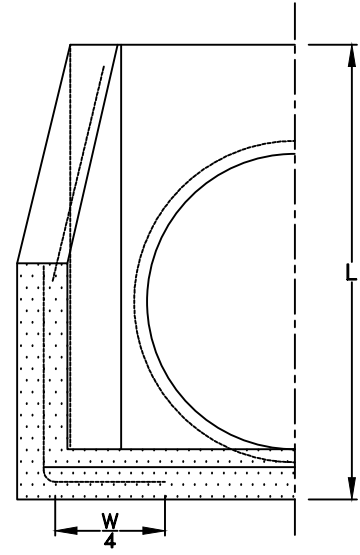
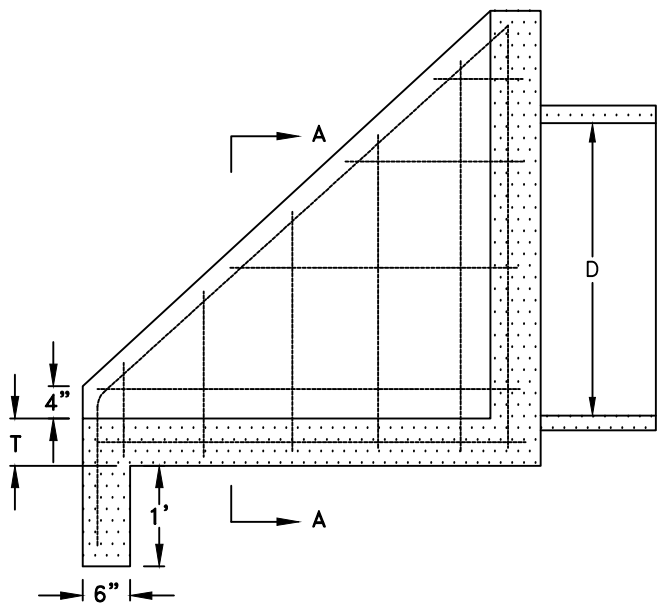

RHON HERNDON
PUBLIC WORKS DIRECTOR

NOTES:

1. "B" MAY BE REDUCED IF REQUIRED BY CHANNEL DIMENSIONS
2. REINFORCING BAR SPACING SHOWN IS MAXIMUM SPACING.
3. ALL CONCRETE TO BE "MINOR CONCRETE" AS DEFINED IN SECTION 71-5B OF THESE STANDARDS.
4. SEE DR-15 FOR TRASH RACK DETAIL.
5. REFER TO DESIGN ENGINEER'S (STRUCTURAL) DESIGN, WHERE FENCING IS REQUIRED.

	DEPARTMENT OF PUBLIC WORKS
	PIPE INLET STRUCTURE
SCALE: NONE REVISED: JANUARY 1, 2021 DRAWN BY: J MCKINNEY APPROVED BY: RHON HERNDON	
DR-13	

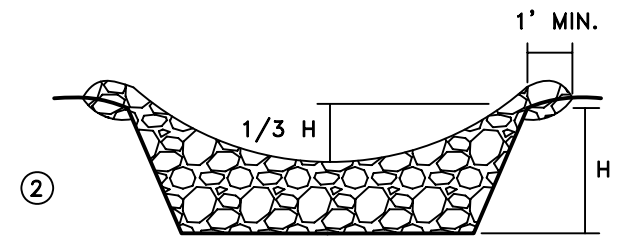
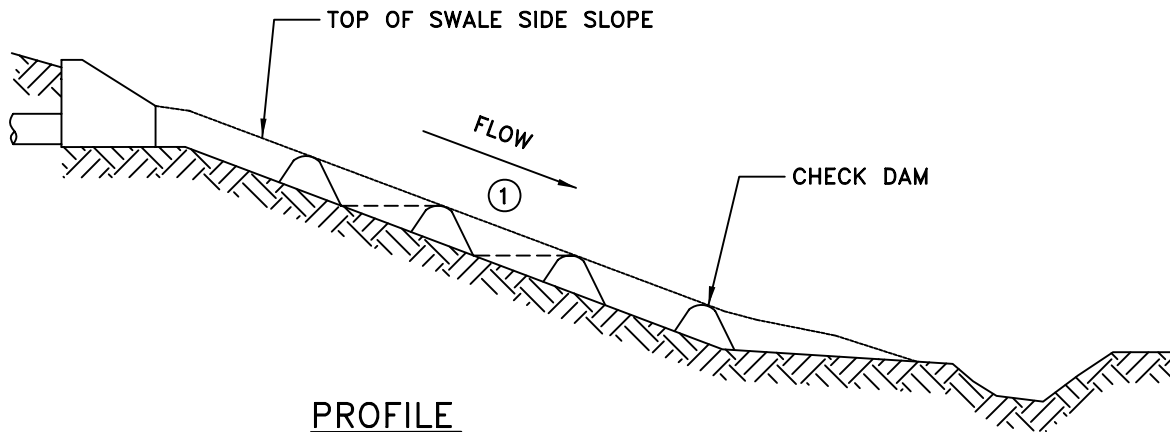

FRONT VIEW

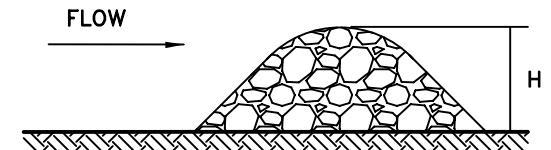

SIDE VIEW

RHON HERNDON

RHON HERNDON
PUBLIC WORKS DIRECTOR

NOTES:

- ① CHECK DAMS SHALL BE SPACED SUCH THAT THE TOP OF THE DOWNSTREAM CHECK DAM ALIGNS WITH THE BOTTOM OF THE UPSTREAM CHECK DAM.
- ② RIP-RAP SHALL BE 4-INCH TO 6-INCH ANGULAR ROCK.
- ③ H = CHANNEL DEPTH



DEPARTMENT OF
PUBLIC WORKS

VELOCITY CHECK DAM

SCALE: NONE
REVISED: JANUARY 1, 2010
DRAWN BY: J MCKINNEY
APPROVED BY: RHON HERNDON

DR-14

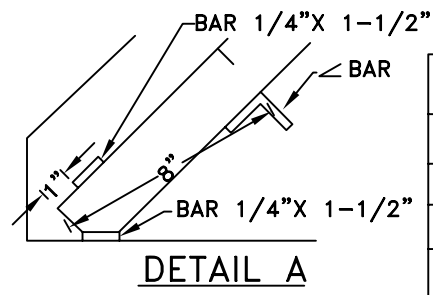
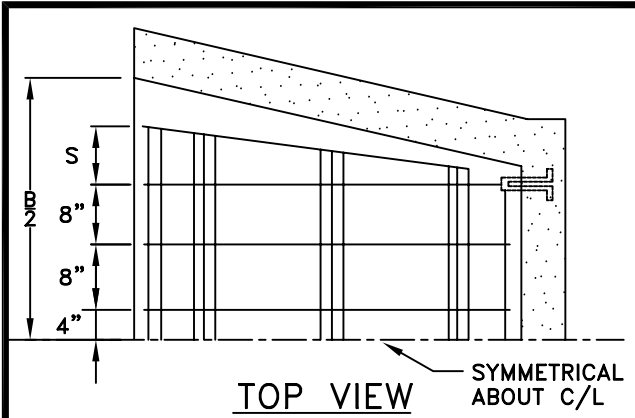

TRASH RACK DIMENSIONS

DIA.	NUMBER & SIZE		L	L'	S	H
	BAR A	L BAR				
33"	8-3/8 X 2 1/2	3-2 X 2 X 1/4	5'-1"	1'-10"	8"	3"-8"
36"	"	"	5'-4"	1'-11"	8"	3'-10"
42"	9-3/8 X 2 1/2	"	5'-11"	2'-3"	9"	4'-4"
48"	"	4-2 X 2 X 1/4	6'-7"	1'-9"	10"	4'-10"
54"	10-3/8 X 3	4-3 X 3 X 1/4	7'-9"	2'-1 1/2"	10 1/2"	5'-8"
60"	11-3/8 X 3 1/2	"	8'-5"	2'-4"	11"	6'-2"

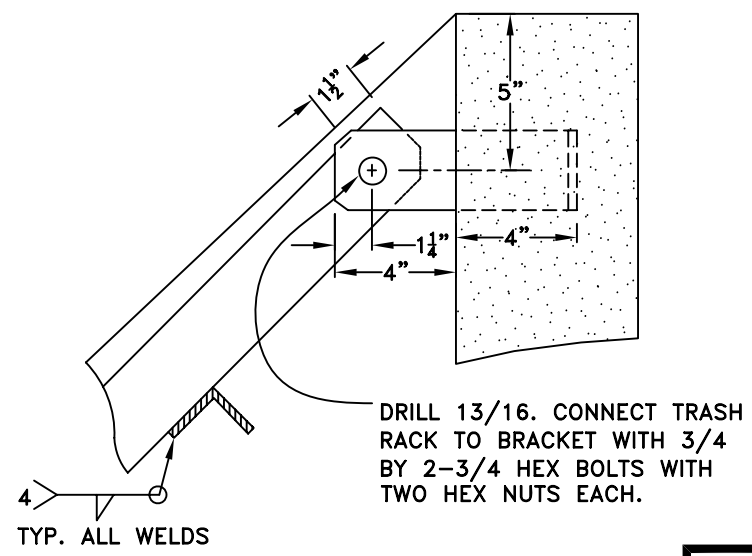
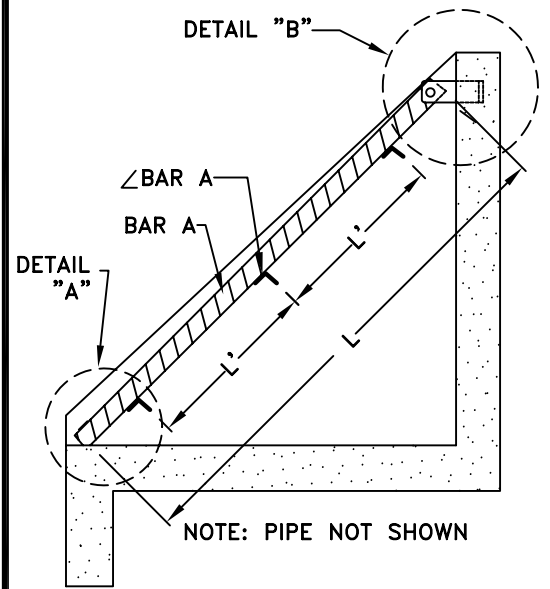

RHON HERNDON
PUBLIC WORKS DIRECTOR

NOTES

1. THIS TRASH RACK MAY BE USED WITH PIPE INLET STRUCTURES.
2. MATERIAL TO CONFORM TO ASTM DESIGNATION A-36.
3. 'S' MAY VARY WITH 'B'. SEE PLATE.
4. ALL FILLET WELDS TO BE 3/16"
5. TWO HINGES REQUIRED FOR 33, 36 & 42 INCH PIPES. THREE HINGES REQUIRED FOR 48, 54 & 60 INCH PIPES.

 DEPARTMENT OF PUBLIC WORKS	
INLET TRASH RACK 33" PIPE OR LARGER	
SCALE: NONE REVISED: JANUARY 1, 2010 DRAWN BY: J MCKINNEY APPROVED BY: RHON HERNDON	DR-15

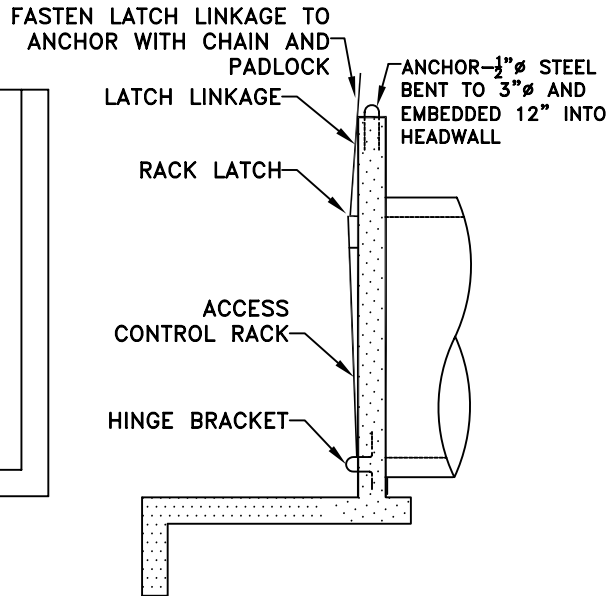
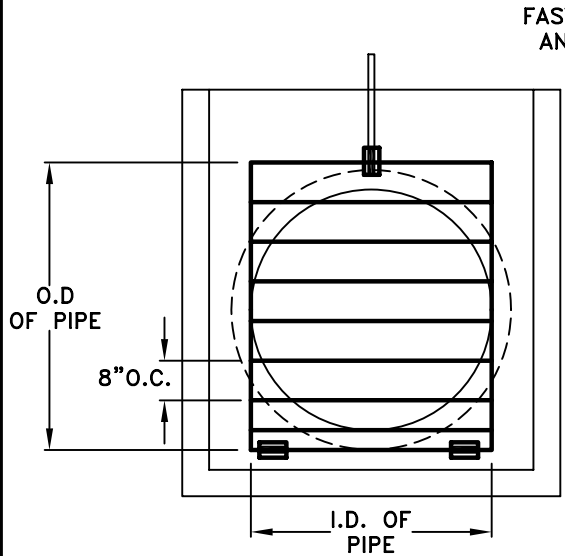

NOTES

1. ENTIRE RACK TO BE WELDED REINFORCING STEEL OR ROUND BARS OF EQUAL DIAMETER WITH HORIZONTAL BARS BEING 8" CENTER TO CENTER.
2. ROOM SHALL BE PROVIDED DOWNSTREAM TO LAY RACK FLAT.
3. FASTEN LATCH BRACKET TO HEADWALL WITH 1/2" X 6" BOLTS WITH HEX NUTS, OR 1/2" EXPANSION BOLTS.
4. WHEN RACK IS IN THE CLOSED POSITION, THE BOTTOM RACK BAR SHALL BE TIGHT AGAINST THE TOP OF THE HINGE BRACKET SO THAT THE RACK CANNOT BE LIFTED OFF THE LATCH.
5. FABRICATE HINGE BRACKET FROM #4 RE-BAR.

PIPE SIZE	RACK BAR SIZE	LATCH PLATE THICKNESS	LATCH LINKAGE SIZE
21"-27"	#4	1/4"	1", .095" THICK
30"-36"	#6	3/8"	1", .095" THICK
42"-54"	#7	1/2"	1", .133" THICK
60"-84"	#8	1/2"	1", .133" THICK

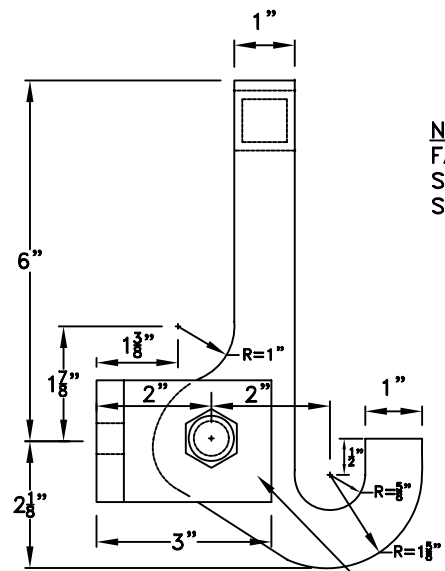

NOTE
FABRICATE LATCH FROM STEEL PLATE, THICKNESS SHOWN IN TABLE

3"X3" STEEL ANGLE
SAME PLATE THICKNESS
AS LATCH PLATE

3"X3" STEEL ANGLE
SAME PLATE THICKNESS
AS LATCH PLATE

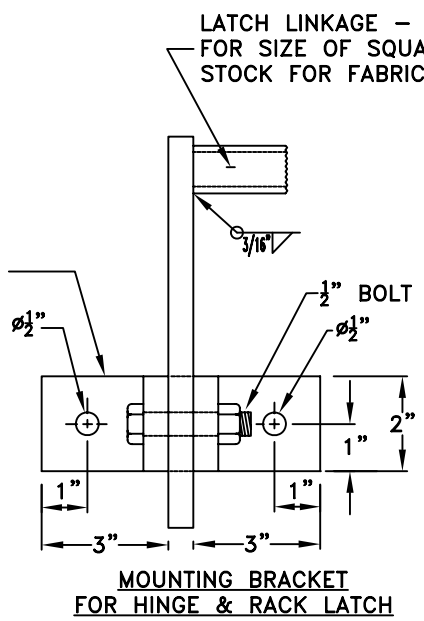

LATCH LINKAGE - SEE TABLE
FOR SIZE OF SQUARE TUBING
STOCK FOR FABRICATION

RHON HERNDON
PUBLIC WORKS DIRECTOR

	DEPARTMENT OF PUBLIC WORKS
--	-------------------------------

TRASH RACK

SCALE: NONE
REVISED: JANUARY 1, 2010
DRAWN BY: J MCKINNEY
APPROVED BY: RHON HERNDON

DR-16

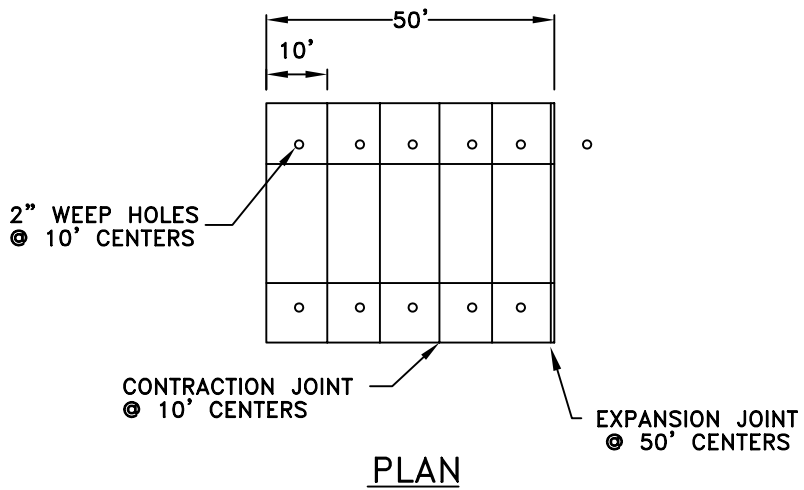
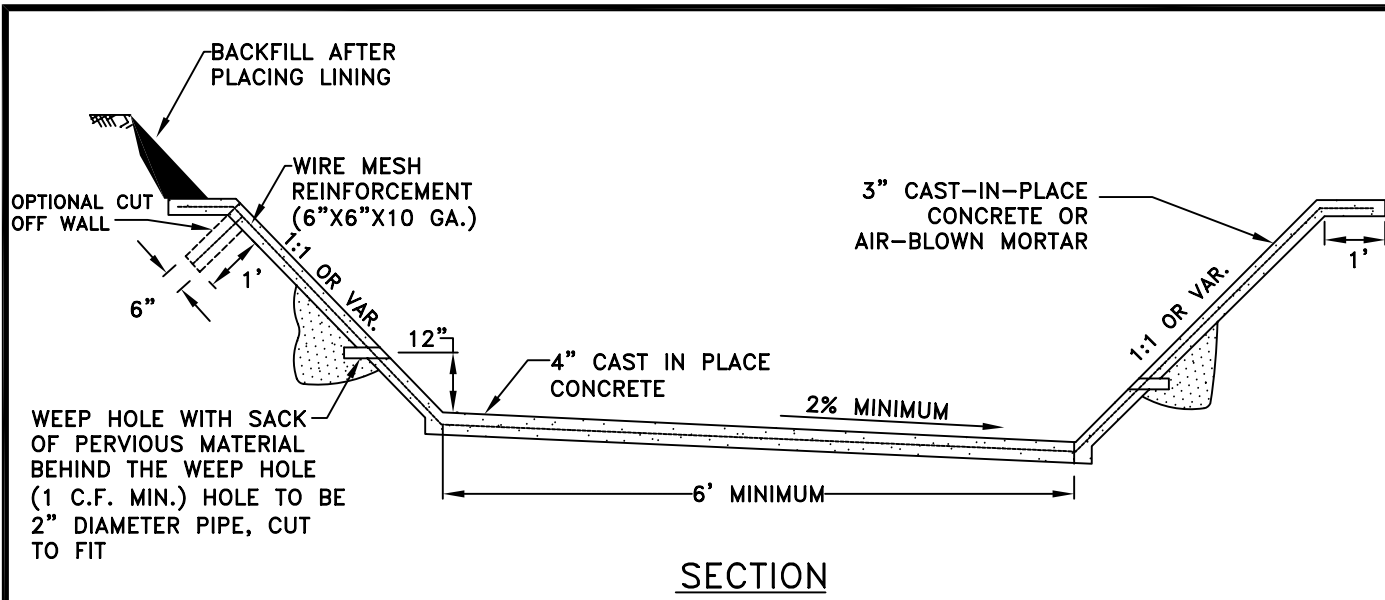

NOTE:

1. ALL CONCRETE SHALL BE "MINOR CONCRETE" AS DEFINED IN SECTION 71-5B OF THESE STANDARDS.

RHON HERNDON
PUBLIC WORKS DIRECTOR

 CITY OF ROSEVILLE CALIFORNIA	DEPARTMENT OF PUBLIC WORKS
LINED CHANNEL SECTION	
SCALE: NONE REVISED: JANUARY 1, 2010 DRAWN BY: J MCKINNEY APPROVED BY: RHON HERNDON	
DR-17	

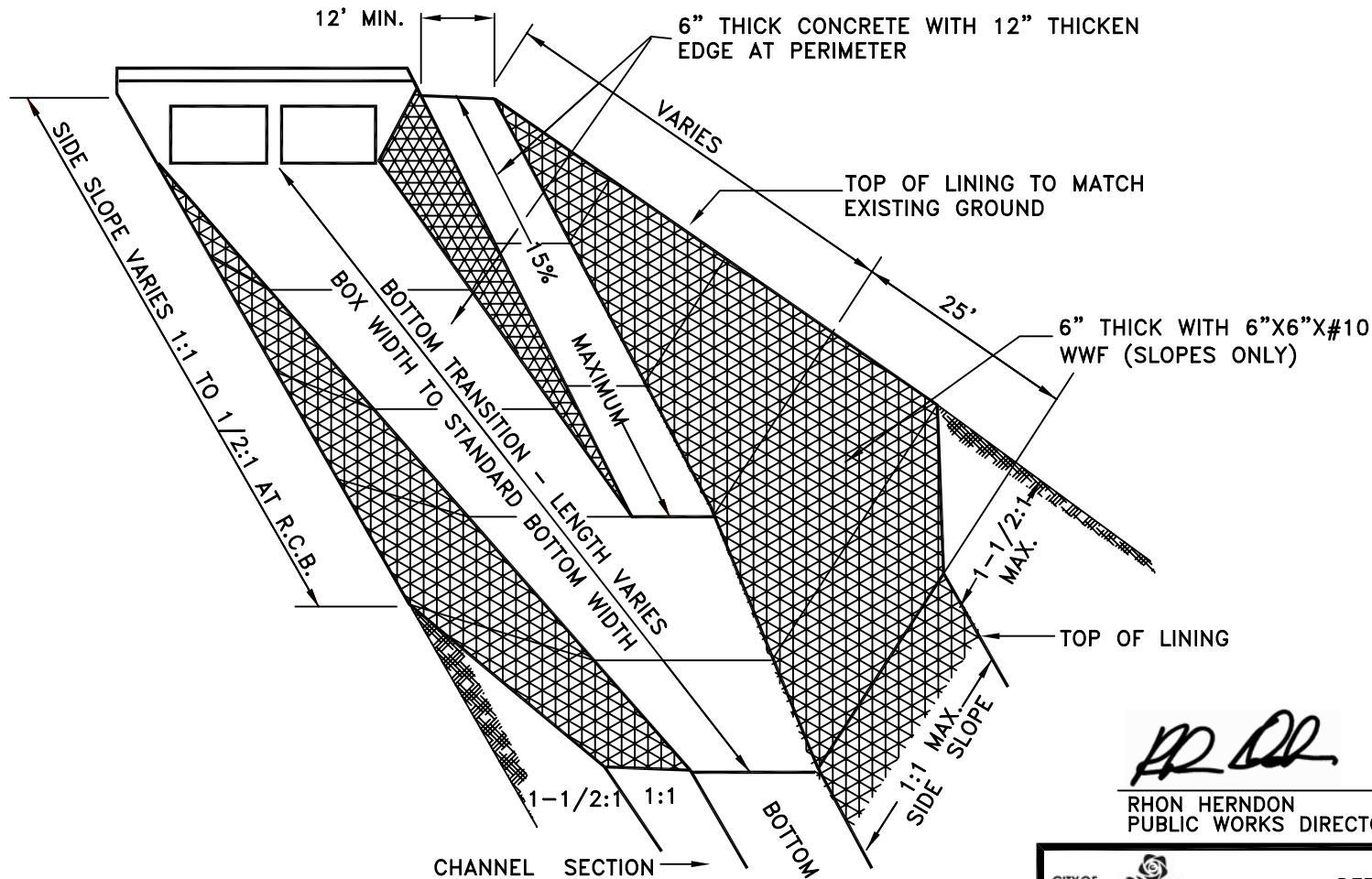

RHON HERNDON

RHON HERNDON
PUBLIC WORKS DIRECTOR



DEPARTMENT OF
PUBLIC WORKS

TYPICAL RAMP & TRANSITION

SCALE: NONE
REVISED: JANUARY 1, 2013
DRAWN BY: J MCKINNEY
APPROVED BY: RHON HERNDON

DR-18

NOTES:

1. BOTTOM TRANSITION 25' MINIMUM LENGTH WITH NO RAMP.
2. WEEP HOLES AND JOINTS AS REQUIRED FOR ALL LINED CHANNEL SECTIONS (SEE DETAIL DR-17).
3. LOW SIDE OF CHANNEL TO BE OPPOSITE RAMP.
4. SIDE SLOPE LINING MAY BE DELETED ON CHANNELS WITH BOTTOM LINING ONLY
5. ALL CONCRETE SHALL BE "MINOR CONCRETE" AS DEFINED IN SECTION 71-5B OF THESE STANDARDS.

MAXIMUM TRENCH DEPTH MEASURED SURFACE TO BOTTOM OF TRENCH IN FEET						
DIAMETER	REINFORCED CONCRETE PIPE -CLASS-					CAST IN PLACE
	I	II	III	IV	V	
10	NOT PERMITTED					NO LIMIT
12		8	12	30		
15		10	15	35		
18		11	16	38		
21		12	17	39		
24		12	18	39		
27		13	19	39		
30		14	19	38		
33		14	20	38		
36		13	17	27	69	
42		14	18	29	62	
48		15	19	30	60	
54		16	20	31	58	
60		14	16	21	31	
66	15	17	22	32	56	35
72	15	18	23	33	56	30

MINIMUM COVER MEASURED SURFACE TO TOP OF PIPE IN INCHES			
TYPE	CLASS	MIN. COVER	
		STREET	OFF ST.
REINFORCED CONCRETE	I	27	12
	II	24	12
	III	18	12
	IV	12	12
	V	12	12
CAST PLACE CONC. PIPE	----	24	12
PVC PIPE		36	24



RHON HERNDON
PUBLIC WORKS DIRECTOR

NOTES:

1. ALL DEPTHS SHOWN ARE FLEXIBLE PAVEMENT AND TRENCH WIDTH EQUAL TO O.D. OF PIPE PLUS 16" FOR PIPE 33" AND SMALLER IN INSIDE DIAMETER.
2. TRENCH WIDTH EQUALS O.D. OF PIPE PLUS 24" FOR PIPE 36" AND LARGER IN INSIDE DIAMETER. TRENCH WIDTH MEASURED AT TOP OF PIPE.

 CITY OF ROSEVILLE CALIFORNIA	DEPARTMENT OF PUBLIC WORKS
TRENCH DEPTH AND MINIMUM COVER REQUIREMENTS	
SCALE: NONE REVISED: JANUARY 1, 2010 DRAWN BY: J MCKINNEY APPROVED BY: RHON HERNDON	
DR-19	

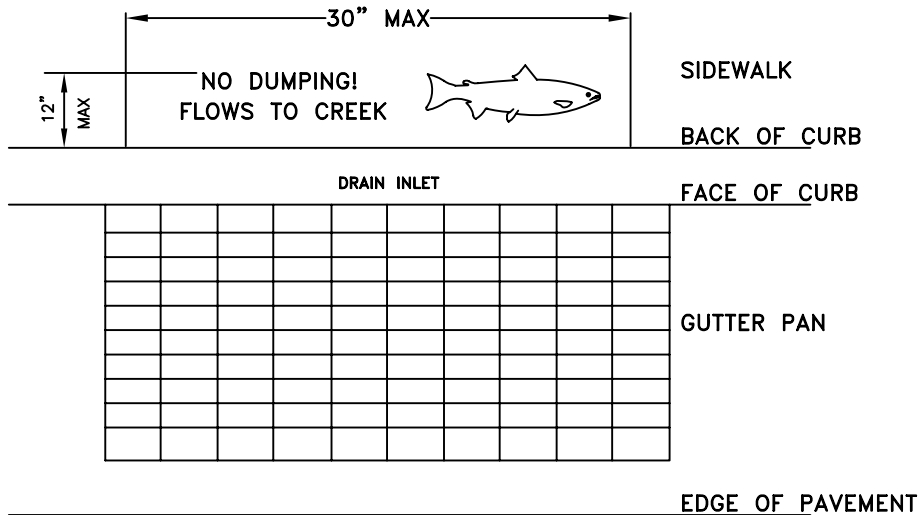

DETAIL "A"

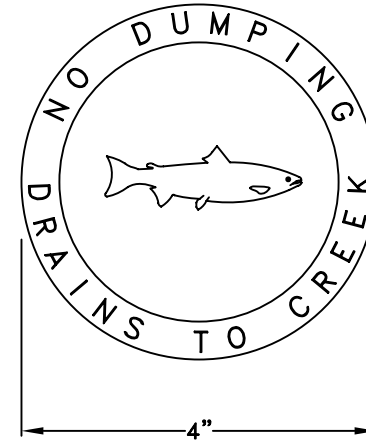

DETAIL "B"

NOTES:

1. DETAIL "A" LETTERING SHALL BE 1 1/4 TO 1 1/2 INCHES HIGH. THE MESSAGE AND SYMBOL SHALL BE DEPRESSED 1/8 TO 1/4 INCH INTO THE CONCRETE. THE FISH SYMBOL SHALL BE A MINIMUM OF 11 INCHES LONG AND 3 1/2 INCHES HIGH.
2. DETAIL "A" SHALL BE PRE APPROVED BY THE CONSTRUCTION INSPECTOR PRIOR TO ITS USE.
3. DETAIL "A" SHALL APPLY TO ALL DRAIN INLET DESIGNS. WHERE THE SIDEWALK DOES NOT ADJOIN THE BACK OF CURB, THE NOTICE SHALL BE STAMPED IN THE CONCRETE BACKUP, BEHIND THE DRAIN INLET. WHERE THE DRAIN INLET IS PLACED IN A "V" GUTTER WITHOUT A CURB INLET, THE NOTICE SHALL BE STAMPED ON ONE SIDE OR THE OTHER, PARALLEL TO THE LENGTH OF THE INLET.
4. DETAIL "B" MAY BE PLACED WHERE DETAIL "A" DOES NOT WARRANT INSTALLATION AT THE DISCRETION OF THE PUBLIC WORKS CONSTRUCTION INSPECTOR. SEE DRAINAGE SECTION 101-8 OF THE DESIGN AND CONSTRUCTION STANDARDS FOR SPECIFICATIONS.
5. THE MESSAGE SHALL BE FREE OF BLEMISHES, LEGIBLE AND ACCEPTABLE TO THE CONSTRUCTION INSPECTOR.

RHON HERNDON
PUBLIC WORKS DIRECTOR



DEPARTMENT OF
PUBLIC WORKS

"NO DUMPING"
PUBLIC NOTICE

SCALE: NONE
REVISED: JANUARY 1, 2010
DRAWN BY: J MCKINNEY
APPROVED BY: RHON HERNDON

DR-20

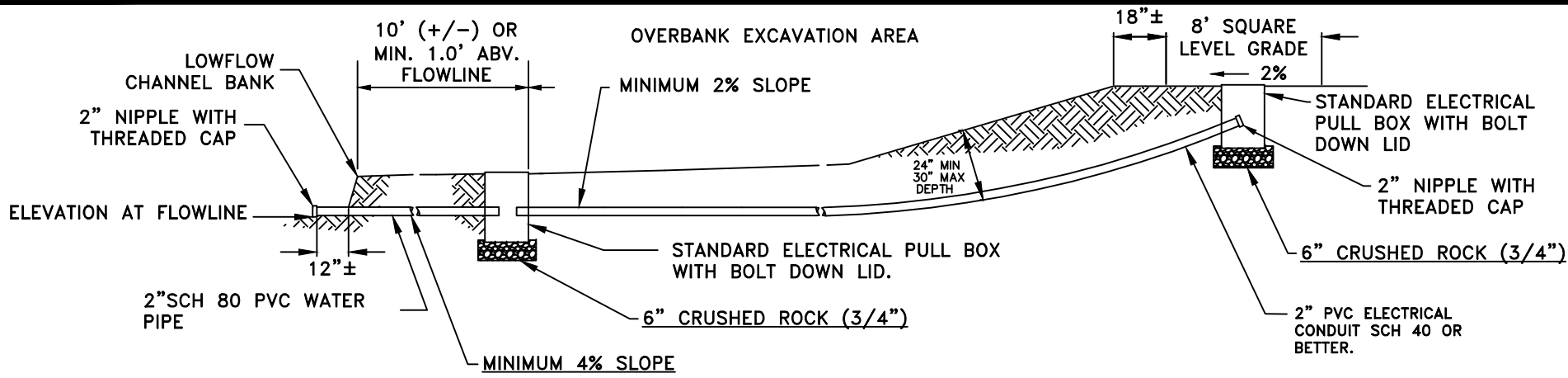

NOTE:
SLOPE PIPES TOWARD THE CREEK.

NOTES ON TYPICAL STREAM GAUGING PAD ADJACENT TO NEW BRIDGE CONSTRUCTION OVER CITY OF ROSEVILLE CREEKS.

EACH STREAM GAUGING CONDUIT WILL HAVE FOUR COMMON PRINCIPAL COMPONENTS:

1. A PAD GRADE AREA 8.0 FEET SQUARE WITH 2% SLOPE TOWARD THE STREAM SIDE. AN ELECTRICAL PULL BOX WILL BE INSTALLED 12 INCHES OFF CENTER OF THE PAD TOWARD THE STREAM SIDE.
2. TWO INCH ELECTRICAL PVC CONDUIT SCH. 40 OR BETTER COMMENCING AT THE ELECTRICAL PULL BOX ON THE PAD AND TERMINATING IN AN ELECTRICAL PULL BOX 10 FEET +/- FROM THE LOW FLOW CHANNEL BANK OR 1 FOOT +/- ABOVE THE LOW FLOW. THE CONDUIT SHOULD NOT INCLUDE ONLY LONG RADIUS ELBOWS TO DROP IT DOWN TO THE APPROPRIATE ELEVATION. A PULL STRING 1/4" NYLON PULL ROPE SHALL BE BLOWN INTO THE CONDUIT FROM THE ELECTRICAL PULL BOX ON THE PAD AREA TO THE ELECTRICAL PULL BOX ADJACENT TO THE LOW FLOW CHANNEL.
3. STANDARD NO. 5 ELECTRICAL PULL BOXES WITH BOLT DOWN LIDS WILL BE USED. THE BOTTOMS OF PULL BOXES SHALL BE BEDDED IN 6 INCHES OF CLEAN CRUSHED ROCK. CONDUIT TERMINATION IN THE PULL BOX SHALL BE A MINIMUM OF 2 INCHES FROM THE SIDES OF THE PULL BOX, 6 INCHES ABOVE THE CRUSHED ROCK. PULL BOX RIM AND LID SHALL BE 1 1/2" ABOVE FINISH GRADE.
4. LOCATION OF THIS STRUCTURE SHOULD BE ON THE UPSTREAM SIDE OF THE BRIDGE AND BE ACCESSIBLE BY FOOT AT ALL POINTS FROM THE LEVEL GRADE AREA TO THE TERMINATION AT THE LOW FLOW CHANNEL. TRUCK ACCESS IS NECESSARY TO THE 8.0 SQUARE FOOT PAD AREA BUT NOT TO OTHER POINTS ALONG THE CONDUIT. ALONG WITH THIS PHYSICAL ACCESS CONCOMITANT RIGHTS OF ACCESS AND/OR EASEMENTS WILL BE GRANTED BY PROPERTY OWNER TO ALLOW FOR MAINTENANCE OF CITY EQUIPMENT INSTALLED ON THIS SITE.

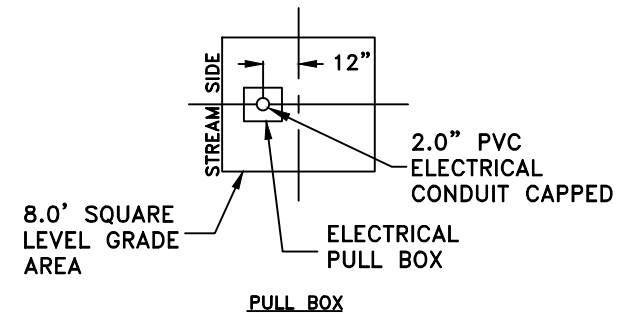

Marc Stout

MARC STOUT
CITY ENGINEER

	DEVELOPMENT SERVICES DEPARTMENT
<h2 style="margin: 0;">STREAM GAUGING STATION</h2>	
SCALE: NONE REVISED: JANUARY 1, 2016 DRAWN BY: J HENDRIX APPROVED BY: MARC STOUT	DR-21

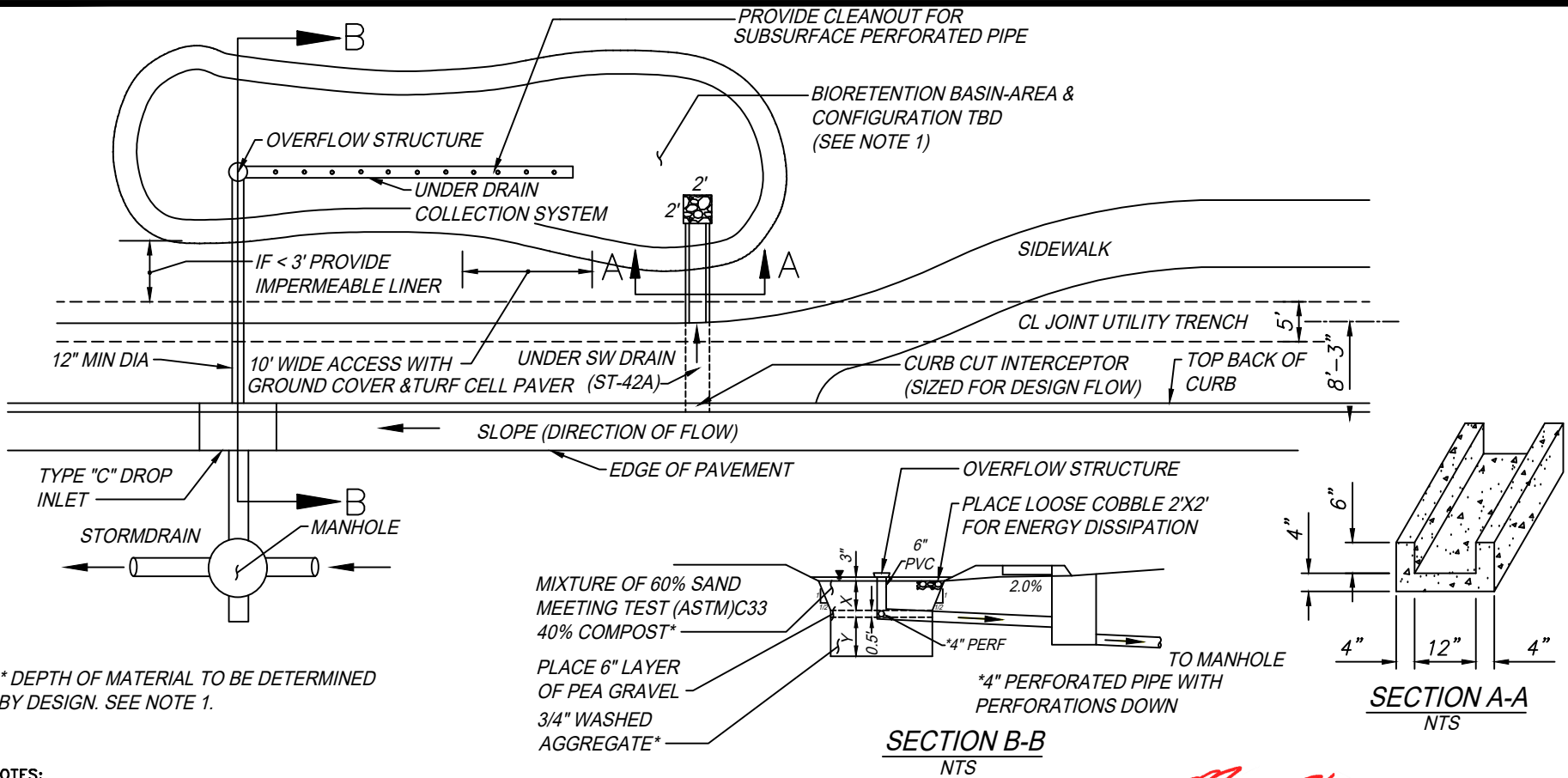

* DEPTH OF MATERIAL TO BE DETERMINED BY DESIGN. SEE NOTE 1.

NOTES:

1. REFER TO THE WEST PLACER STORM WATER QUALITY DESIGN MANUAL (SWQDM) FOR THE DESIGN AND SIZING CRITERIA OF THE BIORETENTION BASIN. CURB CUT INTERCEPTOR, UNDER SIDEWALK DRAIN, AND INLET CHANNEL TO BE SIZED FOR DESIGN FLOW. SHAPE AND SIZE IS CONCEPTUAL ONLY. ACTUAL SIZE AND SHAPE TO BE DETERMINED BASED ON NEED.
2. GRADING TO CONFORM TO SURROUNDING AREA.
3. BASINS TO BE LINED WITH BIOFILTRATION SOD FROM DELTA BLUEGRASS (OR APPROVED EQUAL)
4. WHEN LESS THAN 3' JOINT FROM UTILITY TRENCH, INSTALL 30 MIL LINER ALONG ADJACENT SIDE OF BIORETENTION BASIN PER SWQDM.
5. CONCRETE SHALL CONFORM TO SECTION 71-5B OF THE CITY CONSTRUCTION STANDARDS.
6. PENETRATE HARDPAN (IF IT EXISTS) TO ALLOW FOR BETTER PERCOLATION.
7. ALL IRRIGATION SHALL BE LOCATED OUTSIDE OF THE BASIN.
8. THE OVERFLOW INLET SHALL HAVE A SCREEN WITH 5 mm MAX OPENINGS TO PREVENT TRASH FROM ENTERING THE SYSTEM

MARC STOUT
CITY ENGINEER

	DEVELOPMENT SERVICES DEPARTMENT
<h2 style="margin: 0;">STREET-SIDE STORM WATER BIORETENTION BASIN</h2>	
SCALE: NONE REVISED: JANUARY 1, 2024 DRAWN BY: J. THOMPSON APPROVED BY: M. STOUT	<h1 style="margin: 0;">DR-23</h1>